

VH-MI Ramp Instruction booklet

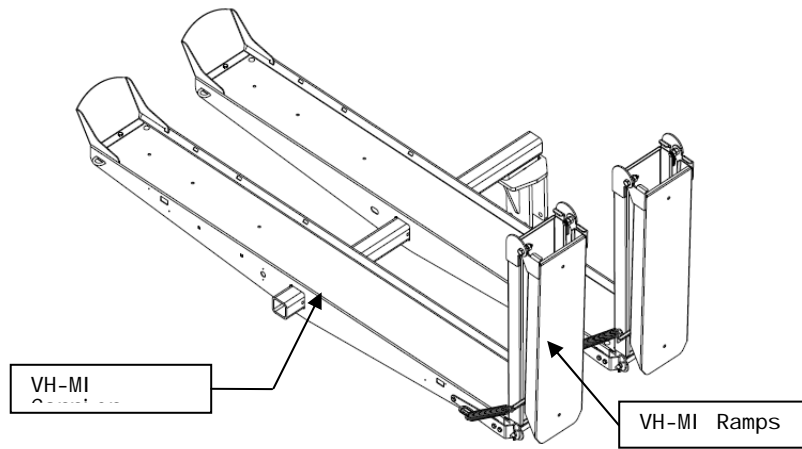

Parts List:

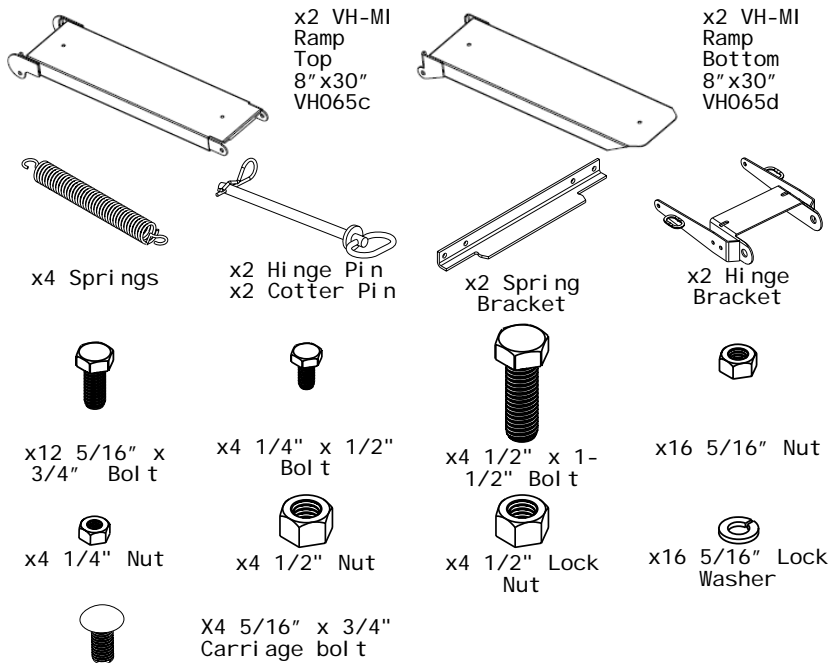

STEP 1

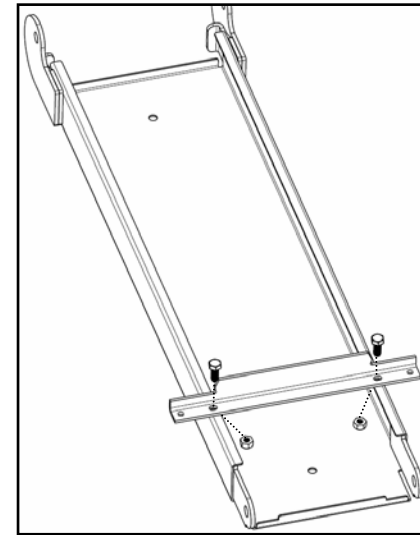

Attach each Spring Bracket to each VH-MI Ramp-top part using all of the 1/4" Bolts and Nuts.

STEP 2

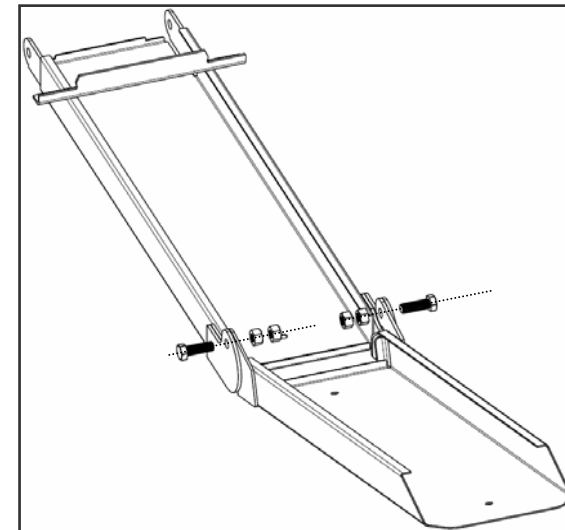

Attach the VH-MI Ramp-Top part to the VH-MI Ramp-Bottom part by screwing the 1/2"x1-1/2" Bolt with the 1/2" Nut, followed by the 1/2" Lock Nut.

STEP 3

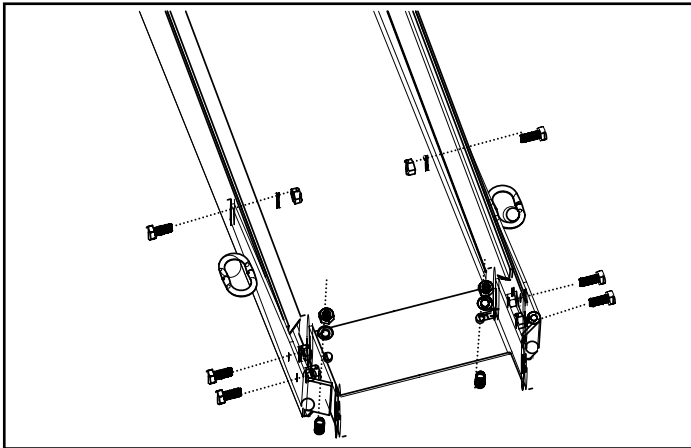

Attach each of the Hinge Brackets to one end of the VH-MI Carrier Rails using all of the 5/16" Bolts, 5/16" Lock Washers, and 5/16" Nuts. The pre-assembled Tie-Down Loops on that end of the rail will need to be removed before assembling the Hinge Bracket. 5/16" Carriage Bolts previously holding the Tie-Down Loops will now be re-screw to hold the Hinge Bracket as well.

STEP 4

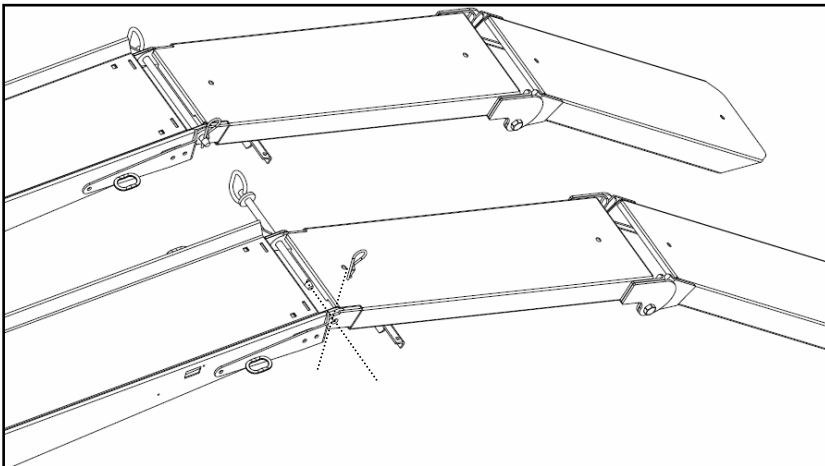

Attach the VH-MI Ramps to the VH-MI Carrier Rails by using the Hinge Pins. Lock the Hinge Pins using the Cotter Pins.

STEP 5

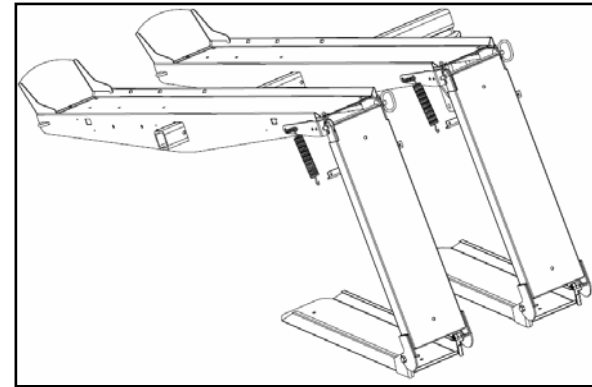

Position the assembled VH-MI as shown and attach the Springs onto the loops on the Hinge Bracket and the outer holes on the Spring Brackets. Once the Springs are attached, pull Ramps upwards to store-position and your VH-MI carrier is ready to be used.

WARNING

A warning indicates a potentially hazardous situation which, if not avoided, could result in death or serious injury.

1. Read all instructions and save them for later reference.
2. Follow all warnings and instructions marked on the product.
3. Do not stand on the Versa-Haul.
4. Do not ride any vehicle during loading.
5. Store Versa-Haul carrier in a safe place.
6. Do not exceed vehicle tongue weight rating.
7. Only use with class III hitch. Most class III hitches limit Versa-Haul to 500 lbs. total hauling capacity.
8. Improper use of carrier could result in death or serious injury.
9. Do not put Versahaul onto a 5th wheel trailer or any other kind of trailer.

Manufacturer Information

Manufacturer's Name: BNK, Inc.

Manufacturer's Address:
BNK, Inc.
9341 S. St. Rd. 39
Winamac, IN 46996
(574) 278-7149

Product Name: Versa-Haul
Product Description: Military Edition Carrier with Ramp Kit

Model Number(s): VH-MI

Serial number

(please fill in serial number affixed to Versa-Haul)