

Instructions for Part # 350ARV, 350ARV-Mini, 500ARV, 500ARV-Plus

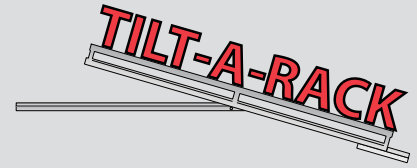

General Guidelines ⚠

- It is the user's responsibility to read and follow all instructions.
- Keep these instructions with the product at all times and review before each use.
- It is the responsibility of this product's owner to furnish the instructions to any person that borrows or purchases the product.
- Inspect the product before use to ensure it is assembled properly and all parts are in safe working order and free of defects.
- Never modify this product in any way.
- All circumstances cannot be addressed in these instructions. Please use common sense and practice general safety measures when using this product.
- Parts and/or instructions are subject to change without notice.

Safety ⚠

- Follow all warnings and instructions marked on the product.
- Do not occupy the mobility aid while loading the carrier.
- Do not stand on the carrier.
- Never exceed vehicle tongue weight rating.
- Do not exceed the carrier weight capacity (350 lbs or 500 lbs depending on model)
- Hitch adapters may affect the weight capacity of the carrier. If using a hitch adapter, always check its limitations before use.
- Always store the carrier in a safe place.
- Improper use, storage, or installation of the carrier could result in death or serious injury.
- Do not put the product on any kind of trailer.
- NOT recommended for tow-behind trailers including 5th wheel trailers and camping trailers.
- Periodically check nuts and bolts for tightness.

Tools Required

- | | |
|---------------------------------------|------------------|
| • Plier or Wire Cutters (to open box) | • Ratchet Handle |
| • 15/16" Wrench | • 15/16" Socket |
| • 10mm Wrench | • 3/4" Socket |
| • Phillips Screwdriver | • 10mm Socket |

Parts

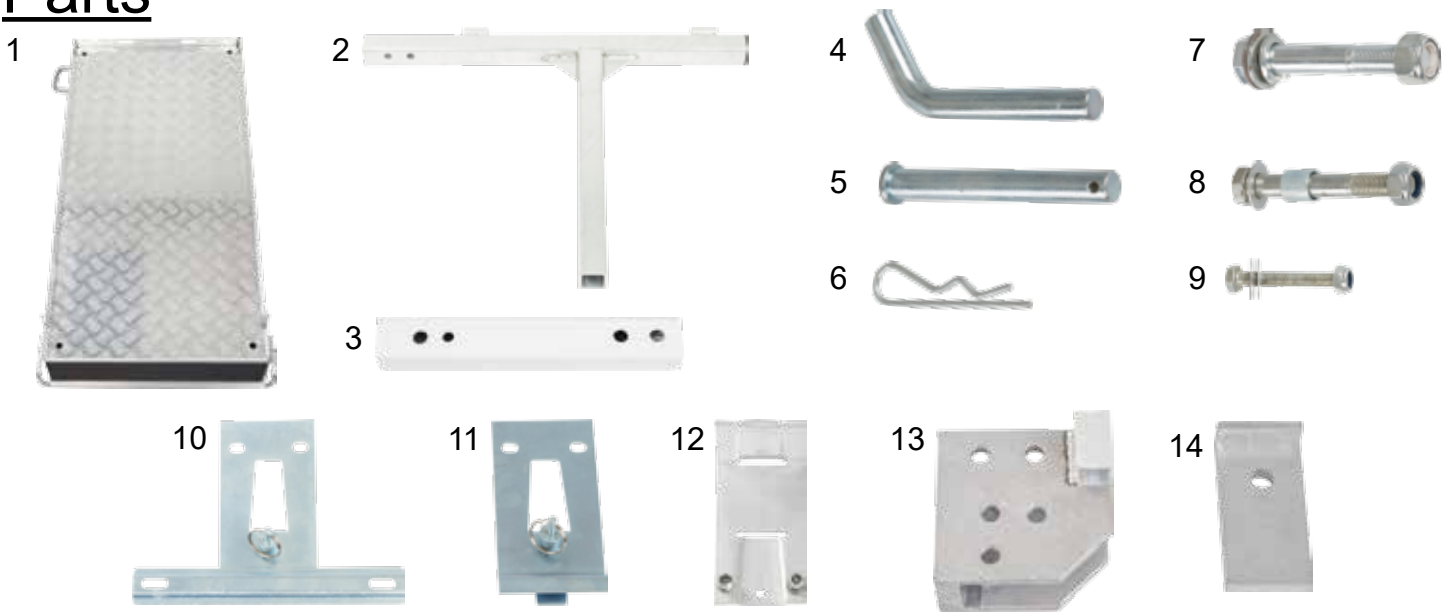

Part	Description	Quantity
1	Carrier Deck	1
2	Main Frame	1
3	Hitch Bar	1
4	5/8" Bent Hitch Pin	1
5	Straight Hitch Pin	2
6	Cotter Pin	3
7	15/16" Bolt, Nut, Washer	3

Part	Description	Quantity
8	Pinch Bolt Assembly	1
9	10mm Bolt, Nut, Washer	1
10	License Hanger	1
11	Light Hanger	1
12	Hanger Adapter with Hardware	2
13	Connection Block	1
14	Deck Stop	1

IMPORTANT NOTE: Although the carrier can be assembled by one person, we highly recommend that you have a helper.

BEFORE YOU BEGIN ASSEMBLY: Be sure to familiarize yourself with the parts and drawing below so your carrier can be easily assembled. We have included references (A, B, C, D, E, F) in the drawing that correspond to the step-by-step instructions on the following pages. This will help you know what area of the carrier you are working on and what parts you will need. Please keep in mind that the parts of your carrier are designed to fit very snugly together so that your carrier is as noise-free as possible.

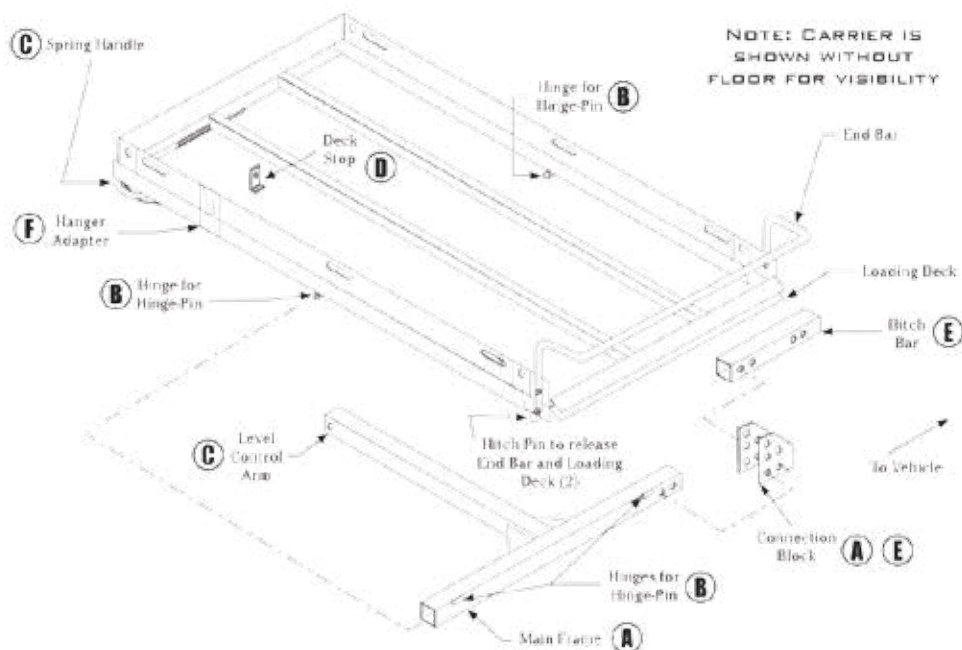

Assembly

Step 1. Place the Connection Block (13) on the Main Frame (2) by locating the set of two holes next to each other.

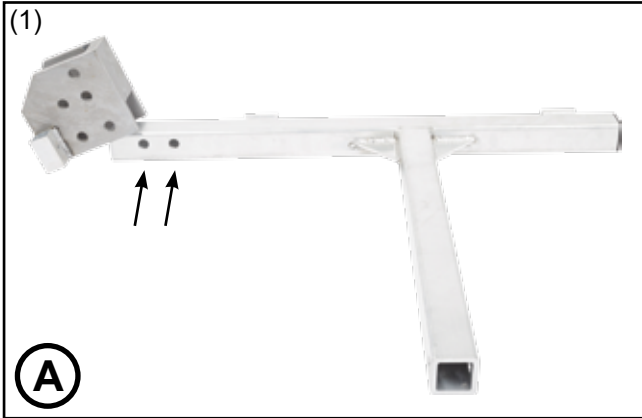

Step 2. Apply two 15/16" bolts (7) with a washer on each side of the Connection Block followed by the lock washer and then the nut for each bolt. Securely tighten both bolts with wrenches. Proper tightness will help keep the carrier quiet during use. See page 7 for details about attaching the Bogie Wheel (sold separately).

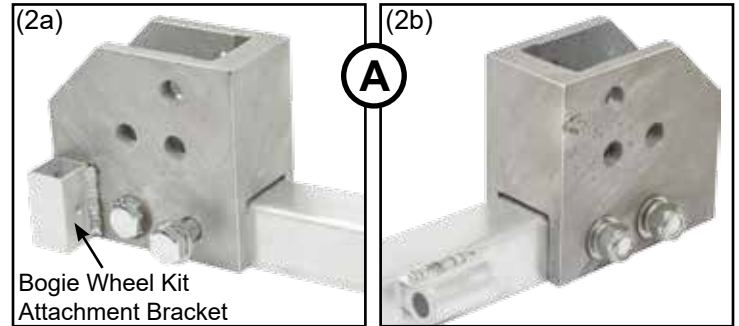

Step 3. Turn the Carrier Deck (1) upside down. Place the Main Frame on it by aligning the two hitch pin hinges. Be sure to align it with the Connection Block on the OPPOSITE side of the spring handle.

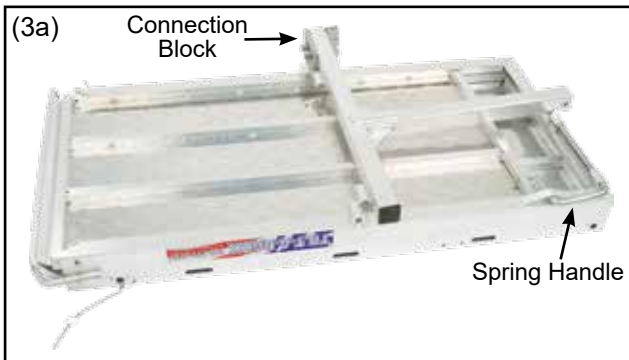

Step 4. Make sure the hinges are aligned and insert a Straight Hitch Pin (5) through the hinges from the inside out. Secure with a Cotter Pin (6). Repeat with the other side. The Cotter Pin will be on the outside of the Carrier Deck, NOT underneath for both sides.



Step 5. Locate the small pin on the end of the spring handle and remove it by pulling it out of the spring handle.

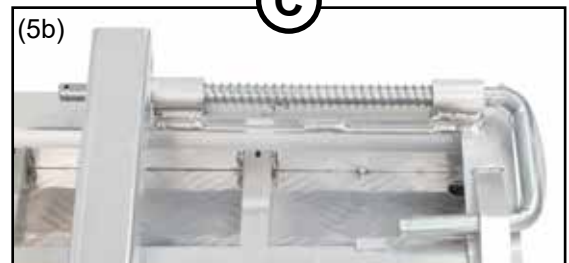

Step 6. Pull the spring handle away from the carrier. Rest the Main Frame on the carrier. Line up the hinges with the hole in the Main Frame. Slowly release the spring handle into its original position (through Main Frame). Pull just the spring toward the handle until you see another small hole in the spring handle. Insert the small pin you pulled from Step 5 in this hole. This creates tension that keeps the spring handle working properly.

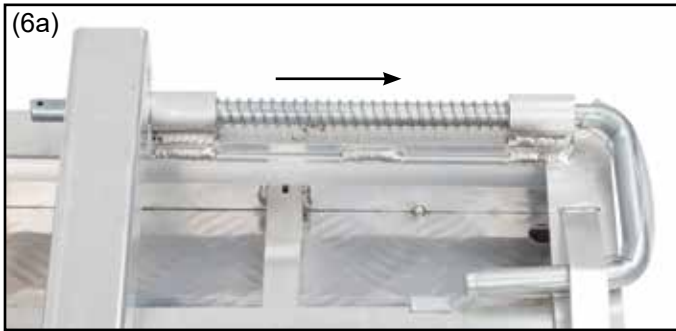

(C)

Step 7. With the Carrier Deck still upside down, locate the small hole in the end of the loading deck. Attach the Deck Stop (14) using the 10mm Bolt (9) with a washer on each side and nut. Tighten with wrench and/or socket wrench.



(D)

*The Deck Stop prevents the loading deck from being extended too far from the carrier deck.

Step 8. Turn the Carrier Deck and Main Frame assembly right-side-up. Place the Hitch Bar (3) into the Connection Block, aligning the two sets of holes.

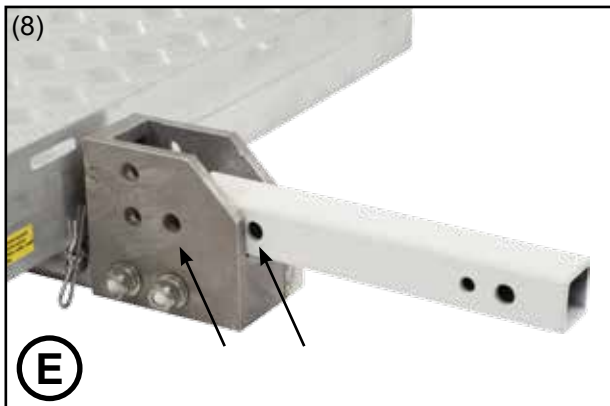

(E)

Step 9. The Hitch Bar should fit snugly so that your carrier is quiet. Install the last 15/16" bolt with a washer on each side, lock washer, and nut as previously done in Step 2. Tighten the bolt with a wrench and/or socket wrench.



(E)

Step 10. When using your carrier, place the Bent Hitch Pin (4) in the lower hole. When storing the carrier, place the Bent Hitch Pin in the upper hole.

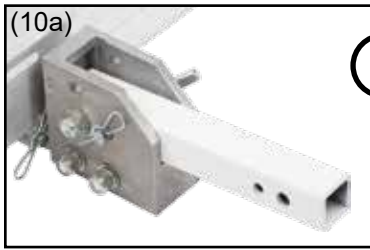

E

Step 11. Locate one Hanger Adapter (12) and install it on the carrier via the two holes near the spring handle. Tighten the Hanger Adapter with a screwdriver and wrench.

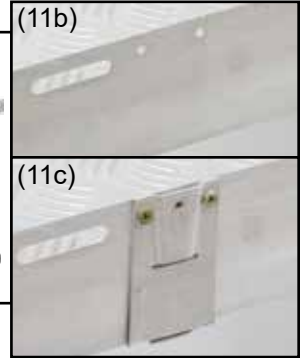

F

Step 12. If you are displaying your license plate on the carrier, use the License Hanger (10). Pull the pin on the front of the Hanger and slide the tab on the back of the Hanger into the top slot of the Adapter. Let go of the pin and it will lock place. If you are just using a light on the carrier, install the Light Hanger (11) instead of the License Hanger.



F

Operation

Step 1. Pull the pins out to release the end bar and loading deck, then rotate the end bar down.

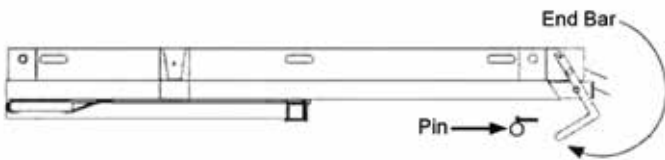

Step 2. With both pins pulled from the carrier, pull the loading deck out.



Step 3. Pull the spring handle away from the carrier to release it from the level control arm. Tilt the carrier down and you are now ready to load your scooter or wheelchair. Secure your scooter or wheelchair to the carrier using tie-downs (sold separately).

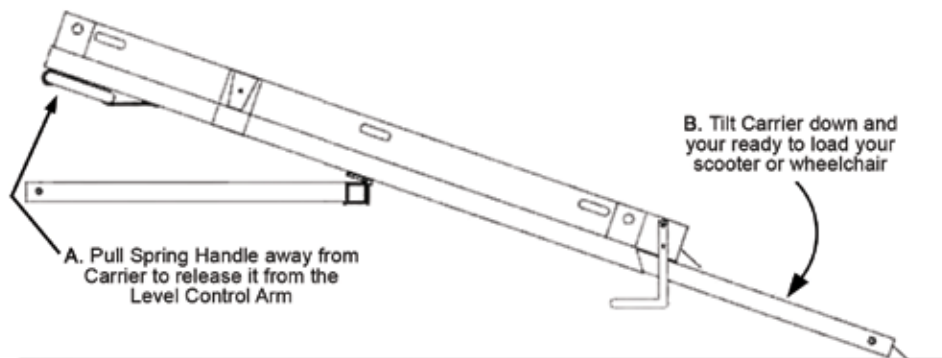

Operation - Pin Location for Use and Storage

As mentioned on the previous page, the carrier has two pin locations for the Bent Hitch Pin. Please refer to the following diagrams when installing the carrier to your vehicle (A) and for storage (B).

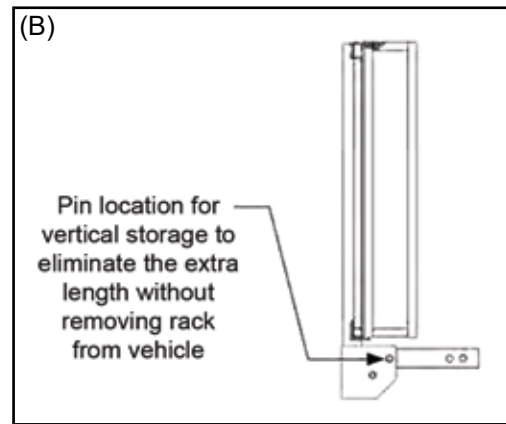
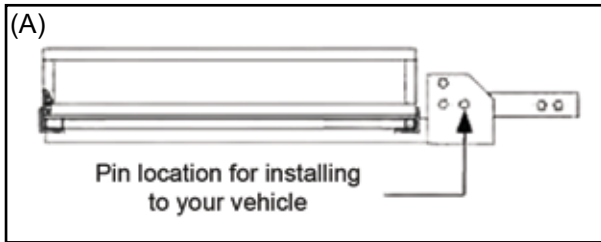

End Bar Operation

Step 1. To secure the end bar during use, rotate it into the upright position as shown.

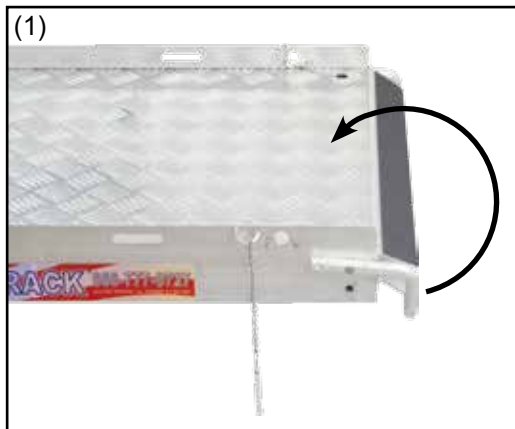

Step 2. Align the small hole in the end bar to the small hole in the carrier unit frame.



Step 3. Using the pins attached to the chain, insert one into the hole on each side of the carrier. Please note that this is a tight fit. To release the end bar, simply remove the pins and rotate the end bar down.



Optional Second Light Hanger: Your carrier came with an additional Hanger Adapter. This would allow you to have a second light if you were displaying your license plate. If you intend to use the second Hanger Adapter, refer to the one that is already attached to the carrier. You will need a drill, a Phillips screwdriver, and a 10mm socket wrench or 10mm wrench.

Pinch Bolt

Optional Pinch-Bolt Installation: Insert Carrier into the hitch and install the Pinch-Bolt assembly as shown below.

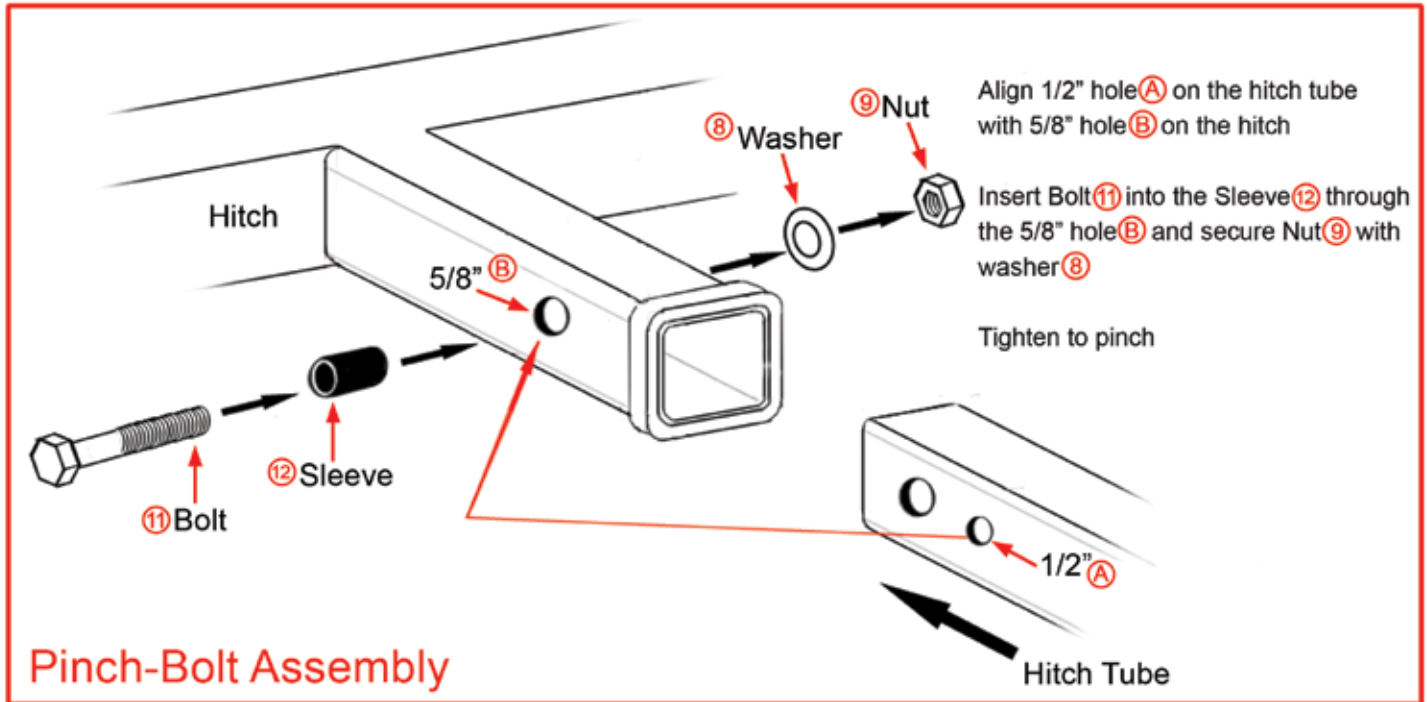

Bogie Wheel Kit

Bogie Wheel Attachment (Sold Separately): The Bogie Wheel Kit attaches to the front of the carrier using the bracket on the Connection Block. This provides easy, single-person maneuverability and quickly detaches when not in use.

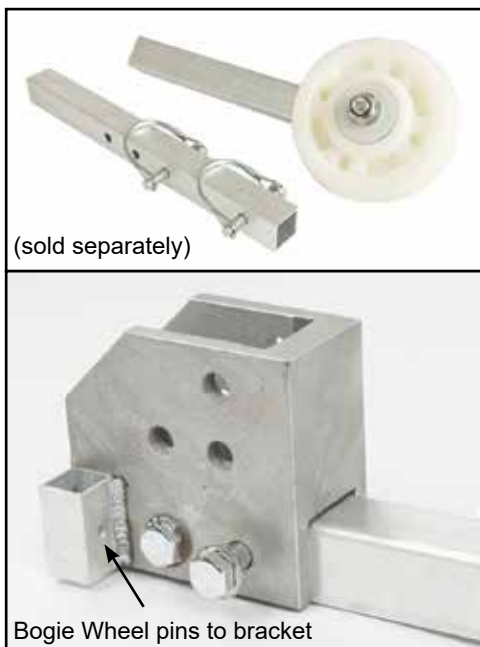

Product Warranty and Liability

GENERAL PRODUCT WARRANTY: Products purchased from the Authorized Dealer (original place of purchase) or Merchant (“Dealer”) will be free of defects in material and workmanship at the time of receipt, and will meet the specifications stated at the place of purchase transaction or online at the Dealer’s website, under normal use and service when correctly installed, operated and maintained. This product warranty is effective for the period of time stated below, unless otherwise stated in the product instructions or depicted in the product advertisement. **All Authorized Dealer warranties are NON-TRANSFERABLE** and cover only the original end purchaser. This limited warranty does not cover products purchased through non-authorized dealers. Non-authorized dealer receipts are not accepted for warranty verification.

*****Warranty claims must be made directly to the original place of purchase.*****

WARRANTY PERIOD: This warranty remains in force for one year from the date of the product’s accepted delivery. The Authorized Dealer offers a one year manufacturer’s warranty for most products unless otherwise specified on the product advertisement.

WARRANTY SERVICE: The Authorized Dealer will replace any defective or malfunctioning part at no charge, including payment of the shipping costs of parts or replacement product to and from the manufacturer. The purchaser is responsible for labor charges. If the product does not meet specifications as depicted in the advertisement, the Authorized Dealer will refund the full purchase price of the product.

Questions regarding the warranty on a specific product and warranty claims should be directed to the Authorized Dealer with whom the purchase transaction was made.

WARRANTY LIMITATIONS: The above warranty does not apply to products that are repaired, modified or altered by any party other than the Authorized Dealer; are subjected to unusual physical stress or conditions (such as overloaded ramps or corrosion), natural disaster, governmental actions, wars, strikes, labor disputes, riots, theft, vandalism, terrorism or any reason beyond reasonable control; are damaged due to improper installation, misuse, abuse, accident or negligence in use, storage, transportation or handling, or tampering; or to products that are considered consumable items or items requiring repair or replacement due to normal wear and tear.

Product should be inspected prior to signing for delivery. Product damage incurred during shipping, unless noted on the Bill of Lading at the time of delivery, renders this warranty void.

LIMITED LIABILITY: In no event shall THE AUTHORIZED DEALER be liable to the purchaser or any third party for any indirect, incidental, consequential, special, exemplary or punitive damages arising out of the use of the product, including, without limitation, property damage, loss of value of the product or any third party products that are used in or with the product, or loss of use of the product or any third party products that are used in or with the product.



DiscountRamps.com
1-888-651-3431
760 S. Indiana Ave.
West Bend, WI 53095