

Proper Strap Location: attach to each side of bike near the rear; strap should pull forward, down and outward. No straps are necessary on the front end of the bike.

Periodic Maintenance:

1. As paint wears off underneath the “fingers” in each shoe, spray a light amount of WD 40 or equivalent on your fingertip and lightly apply to exposed metal to prevent surface rust. The tire should not contact this area during use.
2. Periodically check the pivot points and lubricate if necessary. Movement should be smooth and may be “free” or “tight”, stand should operate equally well in both cases. Periodically check for excessive wear of the brass bushings.

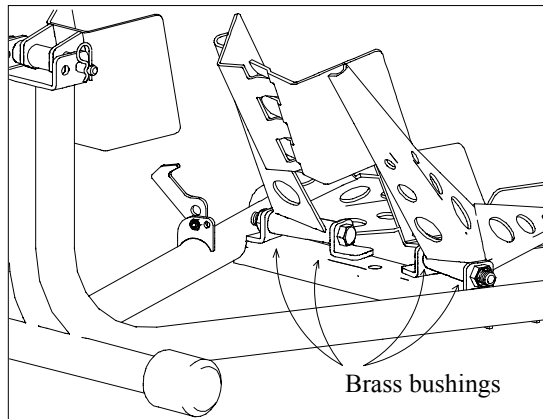

Dear Sport Chock™ Owner:

Thank you for buying one of our unique motorcycle stands. Baxley Trailer Company is a division of Baxley Blowpipe Co. Inc., a small family company that has been in business since 1946. God has certainly blessed this company and the Baxley family in that we have been doing quality work for many of the prominent companies in the Peanut and Woodworking industries. I can brag about our quality in the fact that we are allowed to work for food service people such as M & M Mars, Hershey and Lance Inc. These companies do NOT accept sloppy workmanship.

We have a reputation of fabricating items that work great and will out-last any of our competitors’ products. Whether it’s our unique tilting motorcycle trailers or our patented LA Chock™ or the new Sport Chock™, we strive to provide our customers with the highest level of innovation and quality that can be purchased anywhere. And through our growing network of dealers, you have easy access to parts, accessories and service.

If you ever have a problem that cannot be resolved by your dealer, or if you have any suggestions or comments, please give us a call. We would love to hear from you. It is our desire that you will always have the same joy you had when you first bought this Baxley Trailer Co. product. It is our hope that this Sport Chock™ will last until Jesus comes back to take His children home. It is our prayer that you will be a part of that great home going. May God bless you and keep you safe until then. Romans 6:23.

Because of Him, I am,

Jerome Baxley
President
Baxley Blowpipe Co. Inc.

BAXLEY

Trailer Company

3300 E. Cottonwood Rd.
 Dothan, Al. 36301
 (334) 794-2393
 Fax (334) 671-1351
 www.baxleycompanies.com

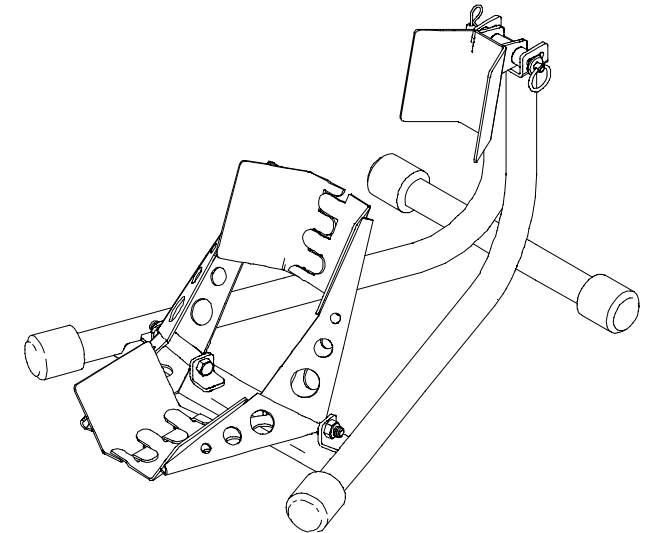

Patented

Sport Chock™

Owner's Manual



CAUTION

BEFORE USING THIS STAND CHECK THE FOLLOWING ITEMS:

- Check that stand pivots smoothly forward and backward and there is no binding of the “fingers” inside each shoe.
- Make sure stand is on firm, level ground and will support the weight of the bike.
- Check that all four rubber feet are in place
- Make sure all bolts are in place and tight.
- Make sure the locking tab is rotated out of the way of the capture mechanism or damage may occur.
- Make sure capture mechanism is rotated rearward and in the ready position.
- When using on a trailer or in a vehicle, make sure the stand is mounted securely down.
- Before towing, make sure motorcycle is securely strapped. See **Proper Strap Location**.

NOTE: TIE DOWNS MUST BE USED WHILE TRANSPORTING A MOTORCYCLE IN A VEHICLE. STRAPS SHOULD HOLD MOTORCYCLE SECURELY FORWARD AND SIDEWAYS

Sport Chock™ Operation:

1. Detach locking tab (if your stand is equipped with one), rotate the capture mechanism rearwards into the ready position.
2. Ride or push the motorcycle into the stand. Aim for the center of the capture mechanism. You will feel the motorcycle roll over a small bump and then the Sport

Chock will automatically capture the front tire and hold the bike upright.

3. If you are leaving the motorcycle for an extended period of time, it is wise to engage the latch to prevent any unintentional disengagement of the stand (particularly in earthquake prone areas). Leaving the bike in gear also gives added security.
4. To release, first make sure bike is in neutral and the locking tab is disengaged. A light rearward pull will release the motorcycle from the stand. If you have extremely hot, sticky race tires, a gentle side to side movement will break any “stiction” and free the bike.

Adjusting the Sport Chock:

The upper shoe has two locations. The “short” location will hold a sport bike tire and allow easy in and out action. The “deep” setting will allow a tire to engage farther into the stand for added stability during transport.

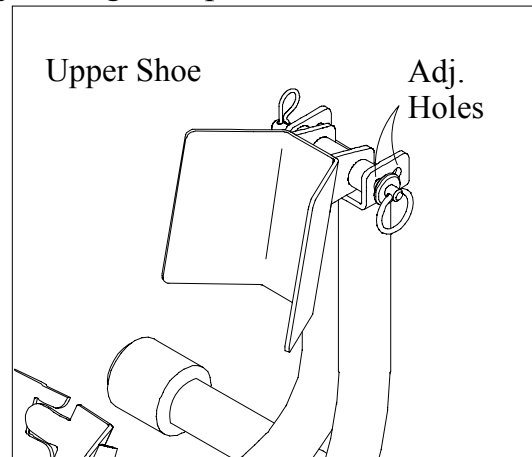

Mounting the Sport Chock™:

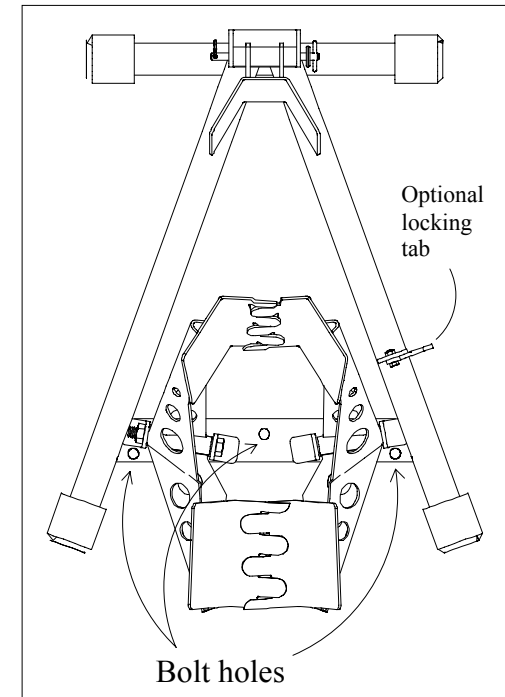

The Sport Chock™ may be placed in the bed of a pickup truck and should not require any further mounting if the bike is strapped down properly. For extra stability in a utility trailer or an enclosed trailer, the stand may be bolted down using one or all mounting locations provided (see above diagram). The center bolt location is recommended for most applications and will provide easy access to the bolt and good stability.

NOTE: Do not over-tighten bolts that hold down the chock. The bolts should be snug enough to provide good grip of the rubber feet but not so tight so as to bend the plate through which they bolt.