

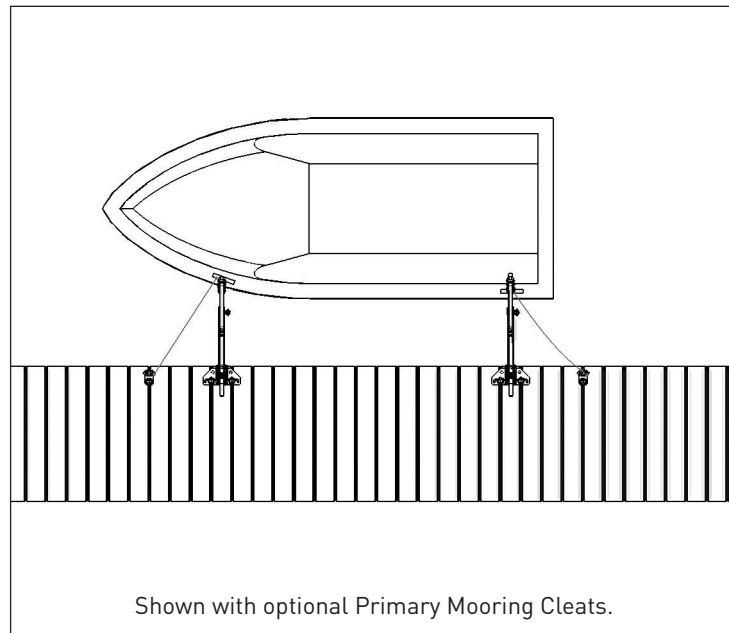

# OWNERS MANUAL

Model 2400



## Portable Mooring System

SAFETY  
OPERATION  
MAINTENANCE  
PARTS

**CAUTION:** Before using your new Pier Tender, read rules for Safety, Operation, and Maintenance.

# CARTON CONTENTS

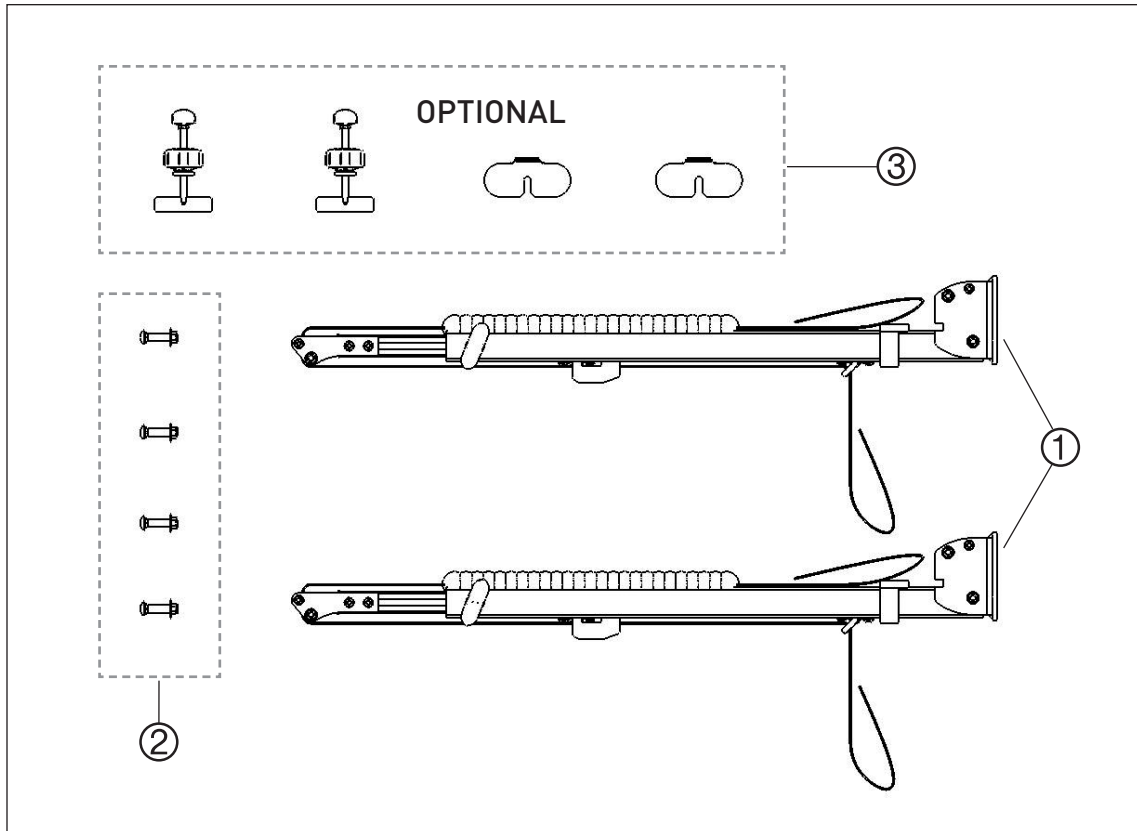

1. Pier Tender Assemblies (2)
2. Fasteners
3. Pier Locks (optional)

# SAFETY RULES

Remember, improper assembly, operation, and/or maintenance of your Pier Tender Portable Mooring System could result in severe damage to your boat/watercraft, the dock or pier to which it is attached and/or may cause serious injury or even death to the person(s) using the Pier Tender as a mooring system.

1. Read the Pier Tender Owners Manual completely before you begin assembly and/or use of this product.
2. Always instruct others before they use the Pier Tender.
3. Do not permit children to operate or use the Pier Tender.
4. Do not use the Pier Tender for anything other than its intended use.
5. The Pier Tender Model 2400 is intended to be used on boats/watercraft up to 24' in length and 5,000 lbs.
6. The Pier Tender is **a supplemental mooring system and MUST be used in conjunction with a primary mooring system or method.**
7. Do not use the Pier Tender as your primary means of mooring your boat/watercraft.
8. Do not use the Pier Tender on permanent docks or piers (anything other than floating docks or piers) in situations where the water levels fluctuate due to current, tides, waves, swells, surges, etc.
9. Do not use in waves that exceed 12" in height.
10. Inspect your Pier Tender before each use and inspect **daily** while in use.
11. **Never** allow the bungee assembly to stretch to more than 80% of its relaxed length of 14."
12. Keep bungee assembly away from fire or excessive heat which may weaken or destroy the bungee assembly.
13. Do not use the Pier Tender if any defects or damage occur to the unit(s) or if there is damage or wear on any portion of the bungee assembly.

# TABLE OF CONTENTS

Carton Contents.....	2
Safety Rules .....	3
Operation .....	4
Maintenance.....	10
Storage.....	10
Service and Adjustments.....	10
Repair Parts Illustration .....	11
Repair Parts List.....	12
Pier Tender Support.....	13

## OPERATION

### MOUNTING YOUR PIER TENDER TO A DOCK OR PIER



**CAUTION:** Your Pier Tender Portable Mooring System is only as good as the dock or pier to which it is mounted. Exercise extreme caution when mounting to any dock or pier, making sure that the dock or pier boards are not rotted, broken, or cracked, and that they are securely fastened to the dock or pier frame.



**CAUTION: Never** mount or use your Pier Tender if the dock or pier boards are cracked, loose, or rotted.



**CAUTION:** Your new Pier Tender is intended for use as a supplemental mooring system and may not be used as a primary or sole means for mooring your boat or watercraft.

## PERMANENT MOUNT

Each Pier Tender base comes equipped with four mounting holes (**Figure 1**) should you wish to permanently mount to a dock or pier. As with the portable mount option, **make sure that the dock or pier boards are in excellent condition and that they are not loose, cracked, or rotted.**

Position your boat/watercraft next to the dock or pier. Using the Pier Tender base and mounting holes as a template, carefully mark the four square holes with a pencil making sure that all four mounting holes are on a board and not over a slot in the dock or pier (**Figure 2**).

**NOTE:** The Pier Tenders should be mounted adjacent to the bow and stern cleats on your boat/watercraft (**Figure 2**).

Drill the four mounting holes in your dock or pier using either a 5/16" or 21/64" drill bit. Mount the Pier Tenders to your dock or pier using the four 5/16" carriage bolts, fender washers, and nuts.

**NOTE:** For the best and safest use of your Pier Tender, the cleats on your boat should be located far enough apart so as to minimize the potential for the bow or stern to hit the dock or pier.

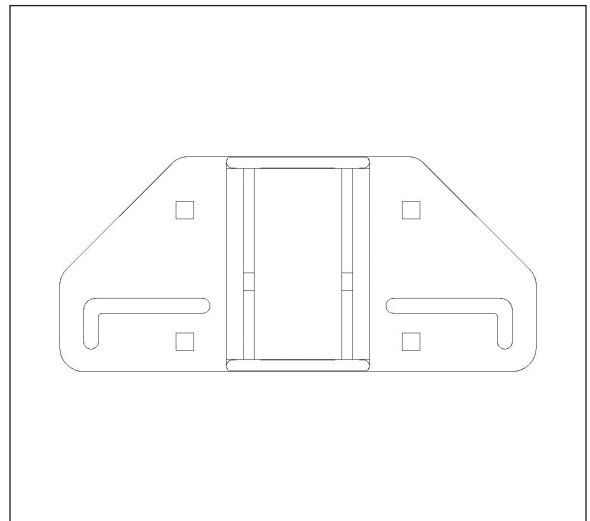

Figure 1

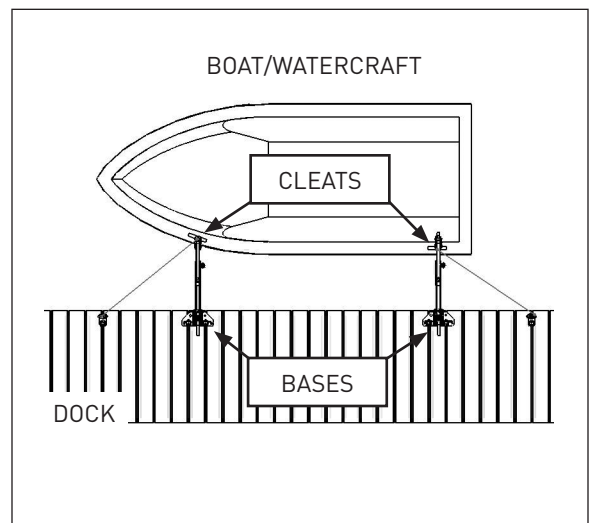

Figure 2



**CAUTION:** As each Pier Tender installation is different, great care must be taken when mounting and using your new Pier Tender to assure safe operation. Make sure that **NO PART OF YOUR BOAT/WATERCRAFT** will come in contact with the Pier Tender arm assembly or bungee/strap assembly during use.

## PORTABLE MOUNT (optional)

To mount your Pier Tender using the Pier Lock mounting clamps, simply locate a position on the dock that is adjacent to your boat cleat and position the Pier Tender so that both of the “L”-shaped mounting slots in the base assembly are directly over a slot in the dock or pier (**Figure 3**). Next, drop the Pier Lock mounting clamps through the base and dock slot. Rotate the Pier Lock 90° so that the fin is perpendicular to the dock slot (**Figure 4**). Next, position each Pier Lock washer to the underside of the dock or pier, between the Pier Lock fin and the dock or pier (**Figure 5**) and tighten the Pier Lock, making sure that the fin is still at 90° to the slot after tightening.



**CAUTION:** Check the Pier Lock mounting clamps often to assure that they are tight and have maintained a 90° orientation to the dock slot.



**CAUTION:** The Pier Tender is a supplemental mooring system and **MUST** be used in conjunction with a traditional method for mooring your boat/watercraft. This applies to both the permanent or portable mounting features of the Pier Tender.

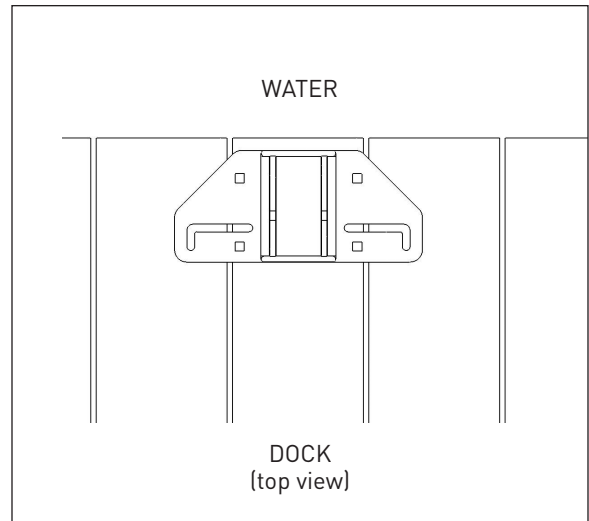

Figure 3

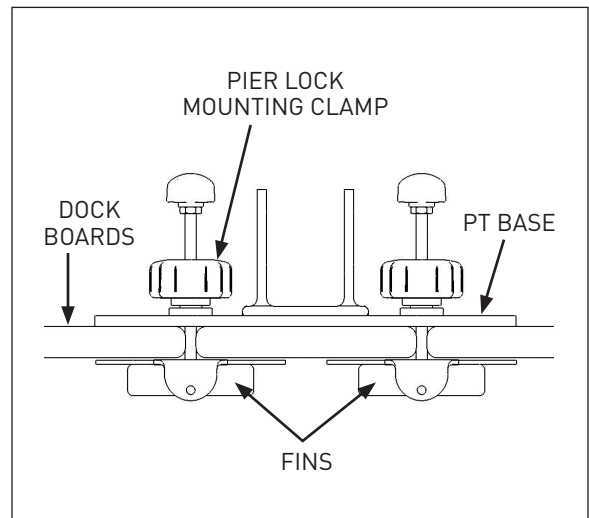

Figure 4

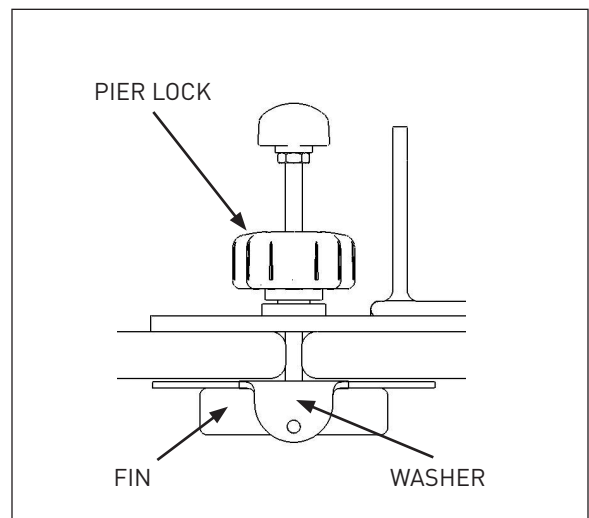

Figure 5

## USING YOUR PIER TENDER

With the boat pulled up to the dock or pier, position the boat so that the boat cleats are adjacent to the Pier Tenders at the bow and stern of the boat. With the arm assembly in the vertical position, depress the button on the cam buckle to release the strap and bungee assembly. Attach the loop end of the strap to the boat cleat (**Figure 6**).

**NEVER** affix the loop of the bungee to a boat cleat by any other method than what is depicted in **Figure 6**.

Your Pier Tender is only as good as the boat cleat to which it is attached. Make sure that the boat cleat is properly attached to the boat and that it can withstand the forces exerted by the Pier Tender as well as external forces such as wind, waves, current, embarking and disembarking, etc. Also make sure that the boat cleat is free of scratches or sharp edges that might cut or wear the loop end of the strap

**ALWAYS** inspect your Pier Tenders to be sure that they are in good working condition. Frequent inspection of the base, arm assembly, mounting, and bungee/strap assembly is mandatory. Discontinue the use of the Pier Tender if any of the above shows any signs of wear.

**NEVER** use the Pier Tender as your sole means of mooring your boat or watercraft. **ALWAYS** use a primary method for mooring your boat or watercraft, with the Pier Tender as a supplemental mooring system.

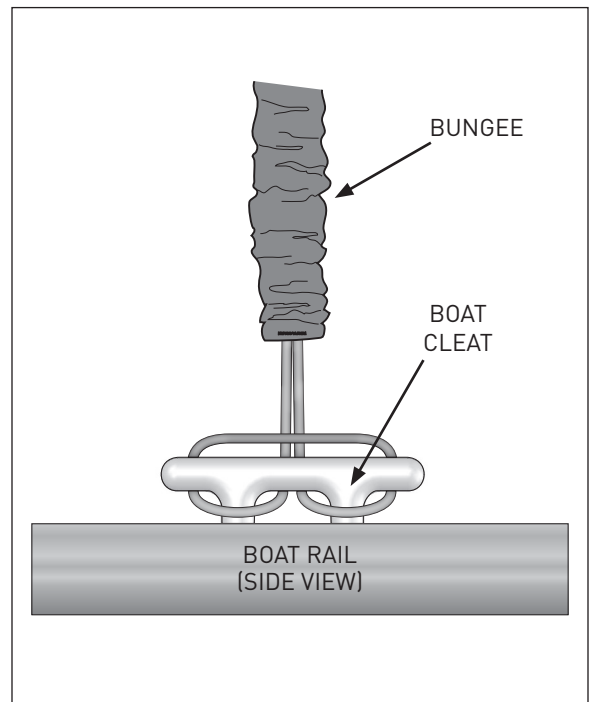

Figure 6

continued ...

## USING YOUR PIER TENDER (continued)

Once the loop end of the bungee and strap assembly has been properly attached to the boat cleat, the Pier Tender arm may be rotated downward until the arm comes to rest on the hard stop (**Figure 7**). To provide tension to the bungee, simply pull up on the strap using the loop at the end of the 1" strap.

**NOTE:** You will want to experiment with the bungee tension for your application as no two applications are exactly the same.

With the arm of the Pier Tender in the 45° position, and with the bungee assembly correctly attached to your boat cleats, the arm assembly may be extended or retracted to position your boat either further away or closer to the dock or pier (**Figure 8**). Loosen the red "T" knob on the side of the lower arm just enough so that the upper arm is free to slide inside of the lower arm. When the upper arm is positioned correctly, re-tighten the "T" knob.

Disconnecting the Pier Tenders from your boat can be done from either inside the boat or from the dock or pier. Simply depress the button on the cam buckle to provide enough slack to the strap so that it can be unhooked from the boat cleat. Once the strap has been unhooked from the boat cleat, manually rotate the Pier Tenders into the vertical position so that they are out of the boats way for departure from the dock or pier.



**CAUTION:** Make sure that the Pier Tender Arm Lock is positioned into the groove on the Pier Tender base assembly when the Pier Tender is in the vertical position (**Figure 9**).

**NEVER** disable the Pier Tender Arm Lock.

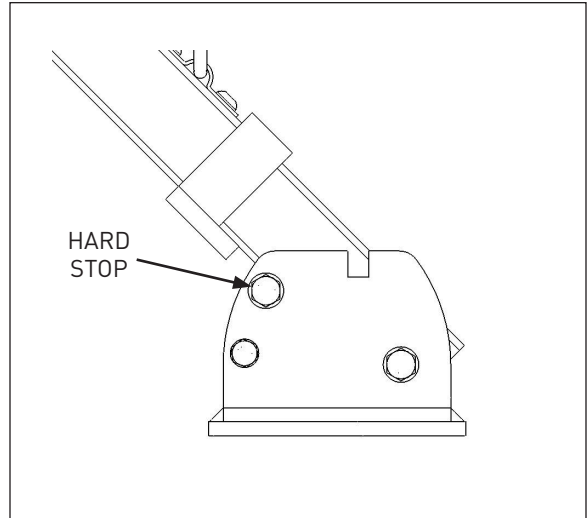

Figure 7

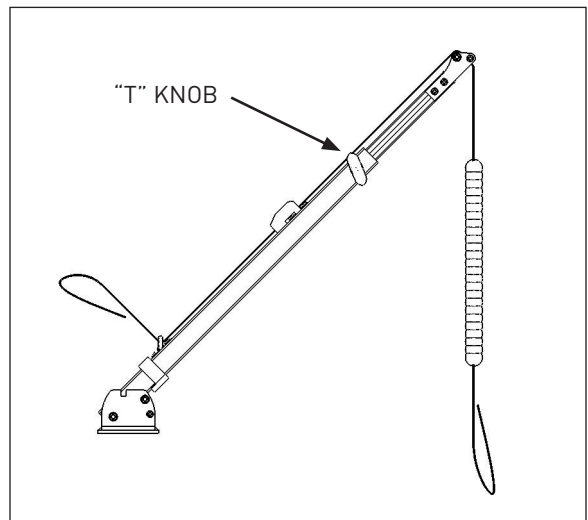

Figure 8

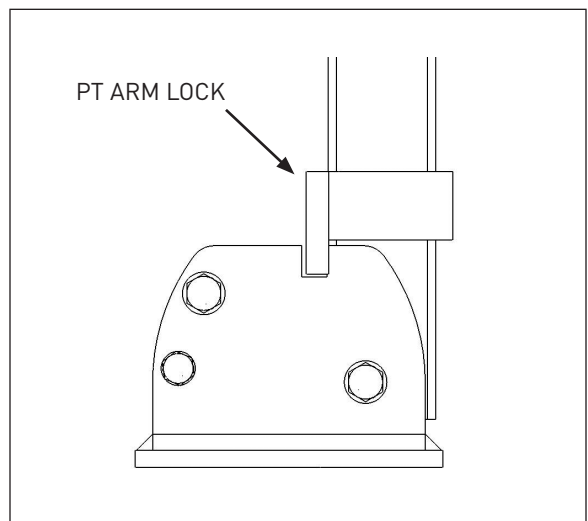

Figure 9

## PRIMARY MOORING SYSTEM SUGGESTION / APPLICATION

As stated several times throughout this Owners Manual, the Pier Tender is a supplementary mooring system and may not be used as the primary means for mooring or docking your watercraft to a dock or pier.

**Figure 10** depicts the top view of a watercraft with the Pier Tender supplemental mooring system attached to both the front and rear cleats of the boat. The **primary mooring system** in this example is the front and rear mooring lines (**Figure 10**) which create a 45° angle away from the Pier Tender and are securely tied to both the watercraft and the dock. This is one example of a primary system which will enhance the performance of the Pier Tender by helping to further stabilize and secure the boat or watercraft from a dock or pier.

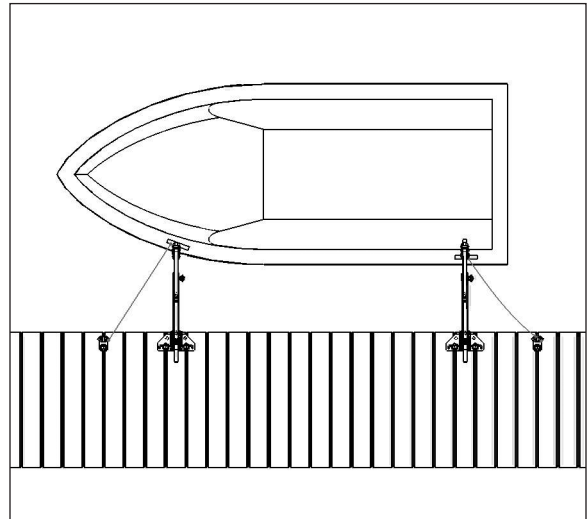

Figure 10

# **MAINTENANCE**

## **CUSTOMER RESPONSIBILITIES**

1. Check for loose fasteners before and during use.
2. Check the bungee and strap assembly for wear and/or damage. Replace damaged or worn component before continued use of the Pier Tenders.
3. Check for worn or damaged parts such as the strap guides, cam buckle, Pier Lock clamps, upper and lower arms, base assembly, and bungee assembly, and replace if needed.

## **STORAGE**

1. Do not put away wet. Always make sure that your Pier Tender is clean and dry before storage.
2. Store in a clean, dry area.
3. Do not attempt to dry any part of your Pier Tender, including the bungee assembly, by placing next to a heat source such as a furnace, oven, radiator, etc. DO NOT put the bungee and strap assembly in a dryer.

## **SERVICE AND ADJUSTMENTS**

1. Periodic adjustments to the tension on the bungee and strap assembly may be required and should be monitored daily.
2. Tightening of the Pier Lock clamps when required. These MUST be checked daily.
3. Make sure that the red "T" knob on the side of the lower arm is hand-tight such that the upper arm is held in place and is not able to slide in or out of the lower arm.

# REPAIR PARTS PIER TENDER MODEL 2400

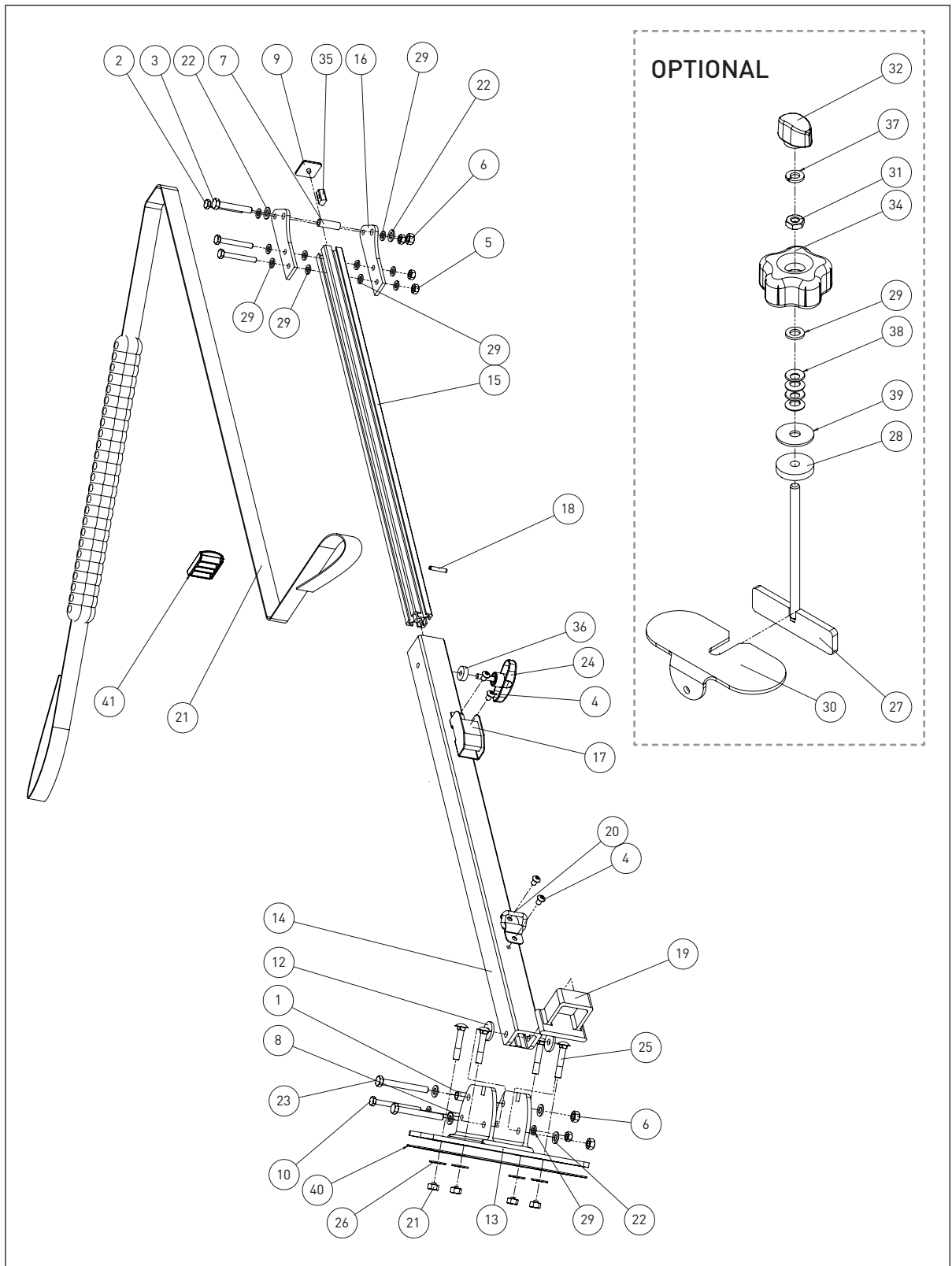

See Page 12 for repair parts list and descriptions.

## REPAIR PARTS PIER TENDER MODEL 2400

Item Number	Part Number	Quantity	Description
1	PT-001	1	0.3125ID x 1.80 Bushing
2	PT-002	3	1/4"-20 x 2" Hex Head Bolt
3	PT-003	1	5/16"-18 x 2" Hex Head Bolt
4	PT-004	4	1/4"-20 x 3/8" Button Head Cap Screw
5	PT-005	4	1/4"-20 Nut
6	PT-006	7	5/16" Narrow Washer
7	PT-007	1	0.250ID x 1.20 Bushing
8	PT-008	1	0.250ID x 1.80 Bushing
9	PT-009	1	Extrusion End Cap
10	PT-010	1	1/4"-20 x 2.75" Hex Head Bolt
12	PT-012	2	.3125ID x 1.000D x 0.125 Plastic Washer
13	PT-013	1	Base
14	PT-014	1	Lower Arm
15	PT-015	1	Upper Arm
16	PT-016	2	Upper Arm Strap Guide
17	PT-017	1	Cam Buckle
18	PT-018	1	Stop Pin
19	PT-019	1	Lock
20	PT-020	1	Tensioning Loop
21	PT-021	1	Bungee Assembly
22	PT-022	6	5/16"-18 Nut
23	PT-023	2	5/16"-18 x 2.75" Hex Head Bolt
24	PT-024	1	"T" Knob
25	PT-025	4	5/16"-18 x 1.75" Stove Bolt
26	PT-026	4	5/16" Regular Washer
27	PT-027	2	T-Bolt
28	PT-028	2	.25ID x 1.000D x 0.1875 Plastic Washer
29	PT-029	14	1/4" Narrow Washer
30	PT-030	2	Dock Washer
31	PT-031	2	1/4"-20 Jam Nut
32	PT-032	2	Alignment Knob
34	PT-034	2	Pier Lock Knob
35	PT-035	1	Tee Nut
36	PT-036	1	.25ID x .750D x .25 Plastic Washer
37	PT-037	2	1/4" Spring Lock Washer
38	PT-038	8	Belleville Washer
39	PT-039	2	1/4" Fender Washer
40	PT-040	1	Base Plate Gasket
41	PT-041	1	Webbing Buckle

# PIER TENDER SUPPORT

## WARRANTY INFORMATION

Pier Tender products are distributed by White Bear LLC. White Bear LLC warrants this product for a period of One Year from the date of purchase. White Bear, at its option, will repair or replace this product or any component of this product found to be defective due to issues with material or workmanship during the warranty period. Replacement will be made with a new or remanufactured product or component. If the product is no longer available, replacement may be made with a similar product, of similar or equal value.

This is your exclusive warranty. DO NOT attempt to repair or adjust any mechanical functions or components on this product. Doing so will void this warranty.

This warranty is valid for the original retailer purchaser from the date of initial retail purchase and is not transferable. Keep the original sales receipt. Proof of purchase is required to obtain warranty performance. White Bear dealers, service centers, or retail stores selling White Bear products to not have the right to alter, modify, or in any way change the terms and conditions of this warranty. This warranty does not cover normal wear of parts or damage resulting from any of the following:

- Negligent use or misuse of the product
- Use contrary to the Owners Manual
- Disassembly, repair, or alterations by anybody other than White Bear or an authorized White Bear Service Center
- Further, the warranty does not cover: Acts of God such as fire, flood, hurricanes and tornados

### **What Are the Limits on White Bear's Liability?**

White Bear shall not be liable for any incidental or consequential damages caused by the breach of any express, implied, or statutory warranty or condition.

Except to the extent prohibited by applicable law, any implied warranty or condition of merchantability or fitness for a particular purpose is limited in duration to the duration of the above warranty.

continued ...

## **WARRANTY INFORMATION (continued)**

White Bear disclaims all other warranties, conditions, or representations, express, implied, statutory, or otherwise.

White Bear shall not be liable for any damages of any kind resulting from the purchase, use or misuse of, or inability to use the product including incidental, special, consequential, or similar damages or loss of profits, or for any breach of contract, fundamental or otherwise, or for any claim brought against purchaser by any other party.

Some provinces, states, or jurisdictions do not allow the exclusion or limitation of incidental or consequential damages or limitations on how long an implied warranty lasts, so the above limitations or exclusions may not apply to you.

This warranty gives you specific legal rights, and you may also have other rights that vary from province to province, state to state, or jurisdiction to jurisdiction.

### **How to Obtain Warranty Service in the USA and Canada**

In the USA and Canada, this warranty is offered by:

White Bear LLC  
P.O. Box 271  
Cedarburg, WI 53012-0271

If you have any questions regarding this warranty or would like to obtain warranty service, please e-mail your claim to [info@whitebearproducts.com](mailto:info@whitebearproducts.com) and a convenient service center address will be provided to you.

Please do not return this product to any of these addresses or to the place of purchase.