

Bike Lift

50 lb. Weight Capacity

It is imperative that you *read* and *comply* with these instructions. Failure to do so could result in personal injury or damage to property.

Mounting Instructions

For best results mount the lift assemblies so the hooks are directly above the seat and handlebar. If you wish, you can mount the entire assembly to a board then mount the board to ceiling joists.

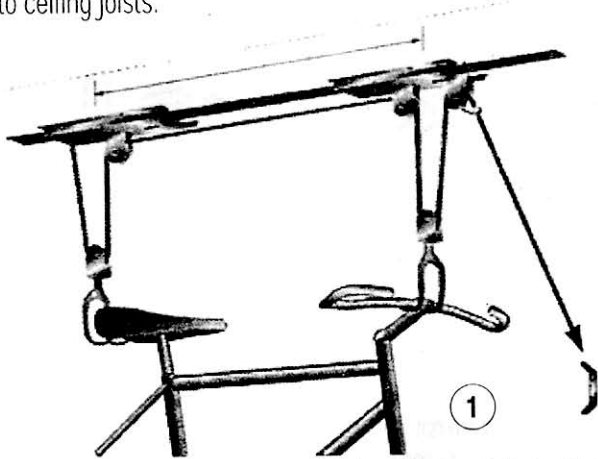

1. Measure the distance between the handlebars and the back of the seat. This is where the hooks will attach to the bike. These measurements will be transferred to the ceiling or a board.

2. Locate a ceiling joist. If your ceiling is covered with drywall, look for nail props, irregularities, and fixtures. These are clues to locating joists. Use a small nail or screwdriver to run a pilot hole into the ceiling to ensure that you've located a joist. Once a joist is located, measure from the wall to the joist. Transfer your seat/handlebar measurement along the joist so the lift attachments line up. If you are planning to mount the lift assemblies in the opposite direction of the joists, you will need to mount the lift assemblies to a board and attach the board to two joists as shown.

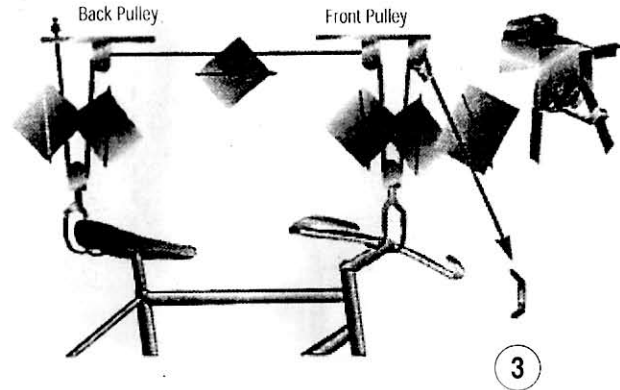
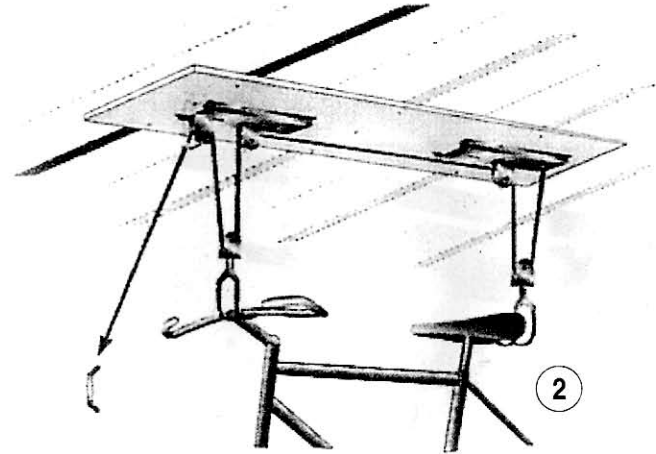

3. Tie a double knot on rope end. Feed rest of rope through square hole on lift assembly. Continue threading the rope through the lift assembly pulleys and hook assembly pulleys as shown.

Parts List:

- 2 - Lift assemblies
- 2 - Hook pulleys

- Tools Required:
- Phillips screwdriver
 - Measuring tape

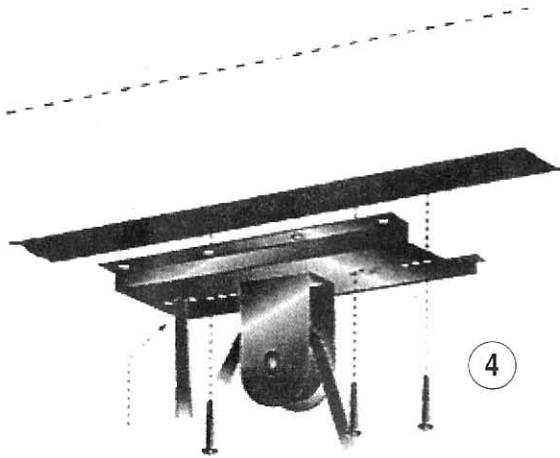
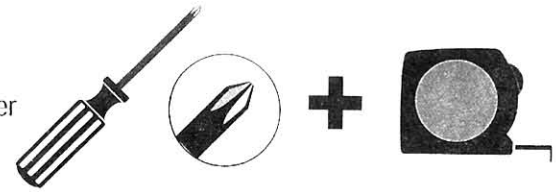

4. Using the wood screws provided, mount each of the lift assemblies (3 screws each) to the ceiling ensuring that the hooks line up with your handlebar/seat measurements.

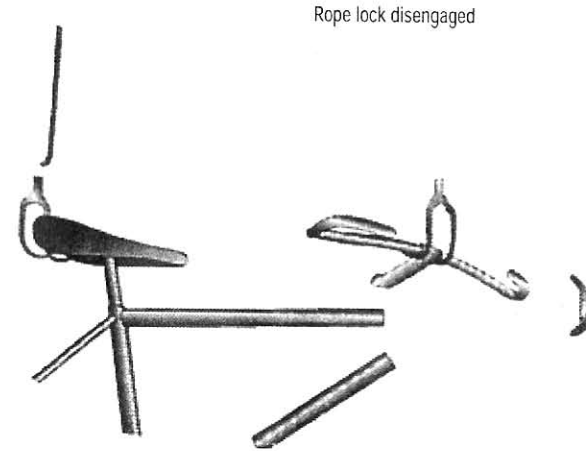

Using the Bike Hoist

Lower the hooks over the bike handlebar and seat. Ensure that the ropes are not twisted. Lift the bike onto the hooks. The bike can then be raised to the ceiling by pulling the rope. Anytime the rope is released the rope lock will engage preventing the bike from falling. For safety, tie off the rope on the cleat and wind the excess rope around it.

Lowering Your Bike

Pull rope towards back pulley maintaining tension on rope (see figure below). Slowly let the rope out as the bike lowers. Letting the rope out too fast will engage the rope lock. When the bike is down remove it from the hooks and raise the hooks to the ceiling. Store excess rope around the rope cleat.

We are not responsible for property damage or personal injury due to improper mounting or overloading.

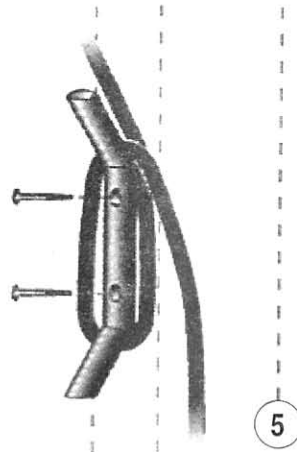

5. Use the remaining 2 wood screws to mount the rope cleat to the wall. Again you will need to find a stud to mount the cleat. Use wall anchors if mounting into a hollow surface. Wall anchors can be found at most hardware stores and home centres. Do not cut rope! Use cleat for excess.