

# RAGE

**POWERSPORT PRODUCTS**

## Assembly Instructions for Cargo Carrier Models:



### Tray Style

- CC-6020
- CC-4820
- CC-F6020
- CC-F4820

### Basket Style

- CCB-6020
- CCB-4820
- CCB-F6020
- CCB-F4820



# Parts List:

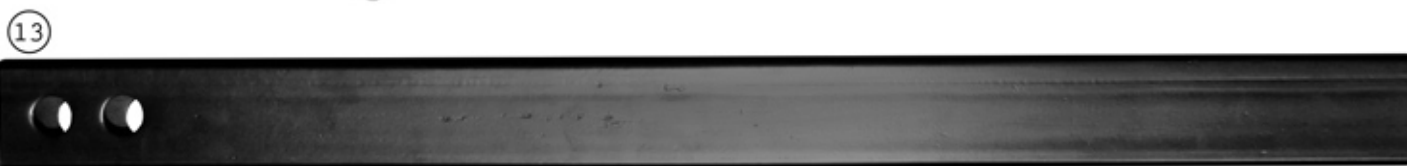
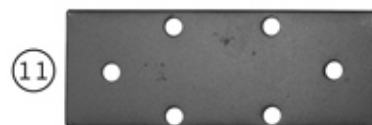

Basket Style

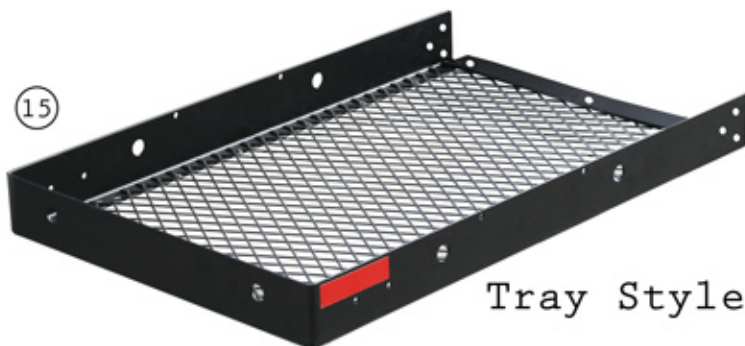

Tray Style

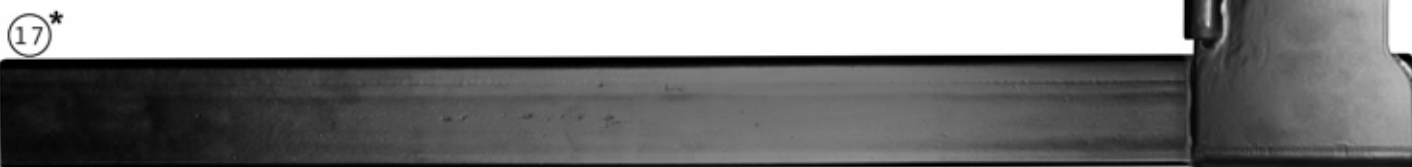
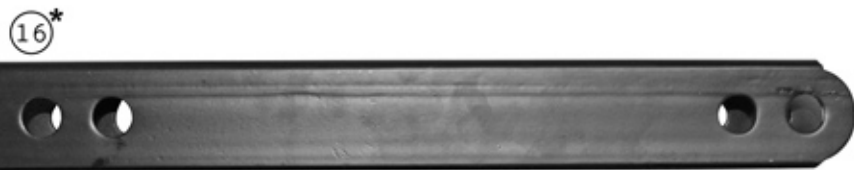

# Part Numbers:

| Index | Description             | Quantity | Part #                           |
|-------|-------------------------|----------|----------------------------------|
| 1     | M10 Nut                 | 7        | CC-M10N                          |
| 2     | M10 Lock Washer         | 7        | CC-M10LW                         |
| 3     | M10 Flat Washer         | 14       | CC-M10FW                         |
| 4     | M6 Nut                  | 12       | CC-M6N                           |
| 5     | M6 Lock Washer          | 12       | CC-M6LW                          |
| 6     | M6 Flat Washer          | 24       | CC-M6FW                          |
| 7     | M6x20 Bolt              | 12       | CC-M620B                         |
| 8     | M10x90 Bolt             | 1        | CC-M1090B                        |
| 9     | M10x80 Bolt             | 2        | CC-M1080B                        |
| 10    | M10x30 Bolt             | 4        | CC-M1030B                        |
| 11    | Joint Plate             | 2        | CC-JP                            |
| 12    | Reflective Sticker      | 2        | CC-RS                            |
| 13    | Receiver Tube           | 1        | CC-RT                            |
| 14    | Support Beam            | 2        | CC-SB                            |
| 15    | Cargo Carrier Section   | 2        | CC-CCB (basket)<br>CC-CCT (tray) |
| 16    | Folding Receiver Tube*  | 1        | CC-FRT                           |
| 17    | Main Tube w/ Bracket*   | 1        | CC-FRB                           |
| 18    | Pin*                    | 1        | CC-HPA                           |
| 19    | Pivot Bolt*             | 1        | CC-PB                            |
| 20    | Pivot Bolt Washer*      | 2        | CC-PBW                           |
| 21    | Pivot Bolt Nut*         | 1        | CC-PBN                           |
| 22    | Pivot Bolt Lock Washer* | 1        | CC-PBLW                          |

\* Please Note: Parts apply to folding cargo carrier models: CC-F4820 CC-F6020  
CCB-F4820 CCB-F6020

\* Trailer Hitch Pin not included.

# Step 1: Basket Assembly

Slide Cargo Carrier sections <sup>15</sup> together...

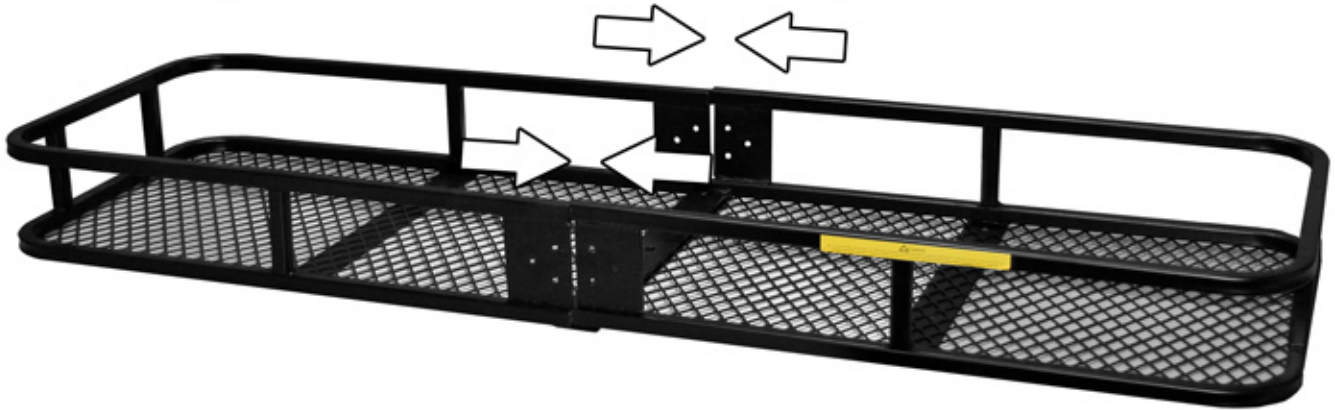

... and secure with Joint Plates <sup>11</sup> using Figure 1

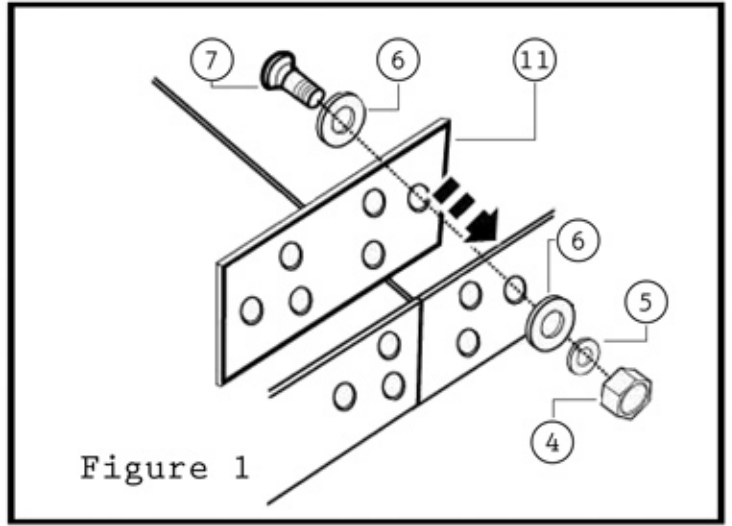
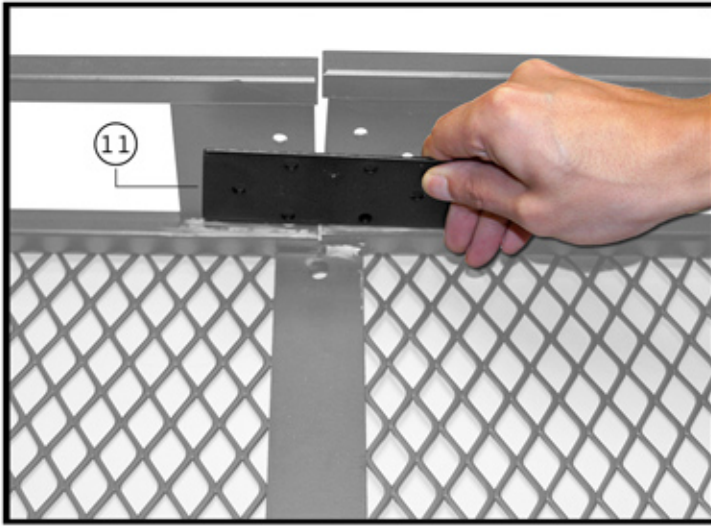

2. Flip carrier for hitch tube and support installation.

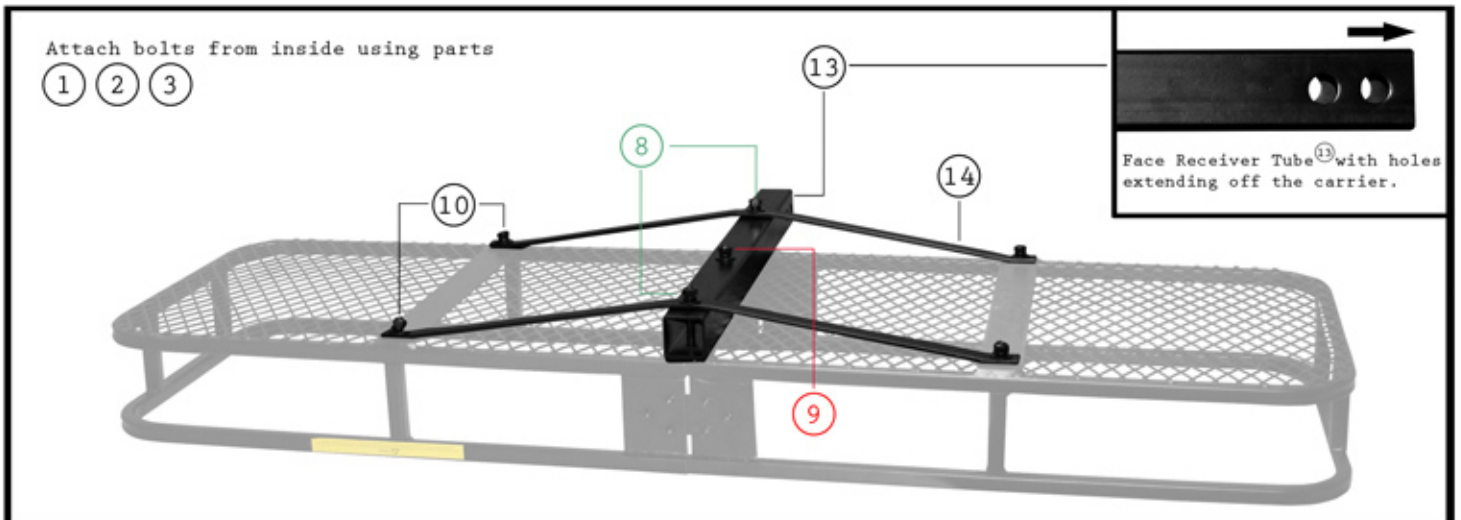

# \*For Folding Models:

CCB-F6020

CCB-F4820

CC-F4820

CC-F6020

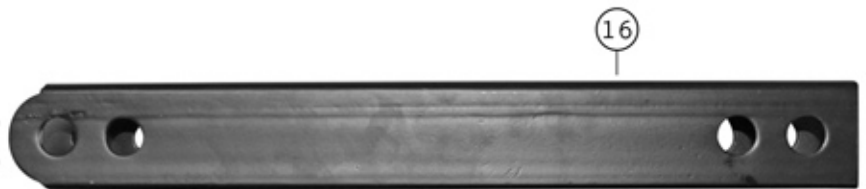
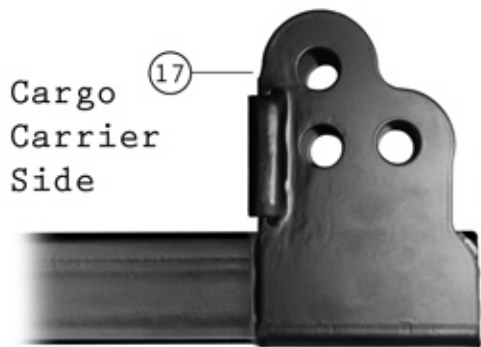

Insert the rounded end of the folding receiver tube into the main tube bracket.



Secure Folding Receiver Tube (16) with Pivot Bolt (19)\* and Pin (18) to main tube bracket (17)

## \* Pivot bolt assembly (side view)

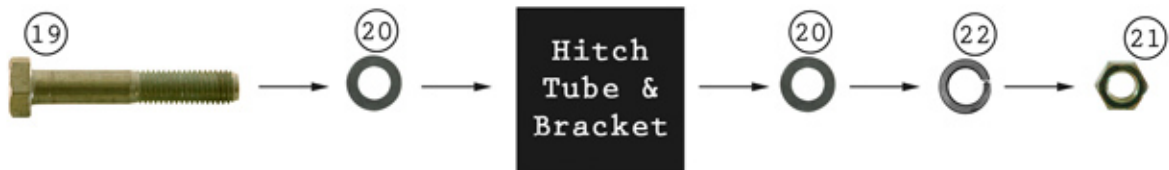

To fold the carrier vertical, remove Pin (18) and fold carrier. Align holes and reinstall Pin (18) in top main tube bracket hole.

Cargo Carrier Side

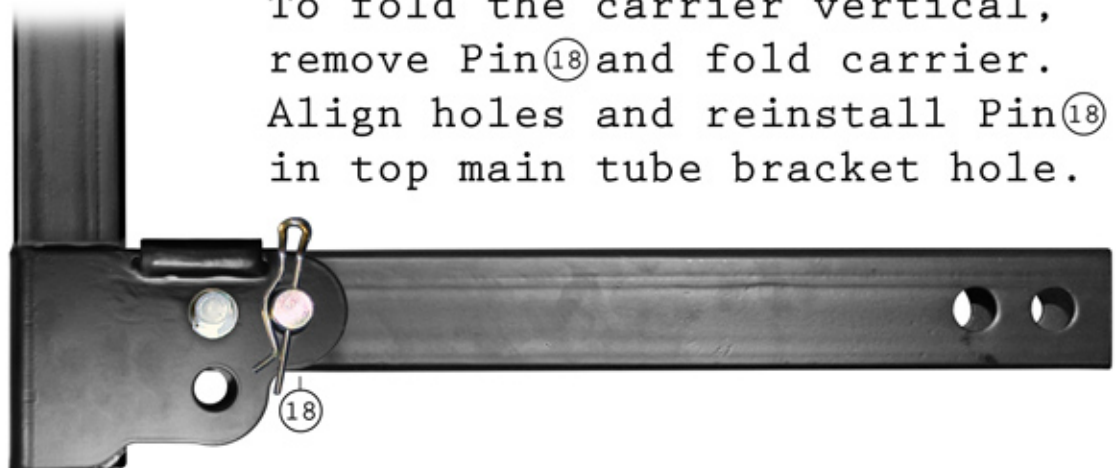

# Rail Install

Models: CC-4820 & CC-6020  
Sold Separately

## Parts List



## Assembly

1. Attach the (2) rails with (2) crossbars using the (4) crossbar bolts to create the rail framework.



2. Align the rail assembly over the CC-4820 or CC-6020 and drill (8) holes into the carrier for rail attachment. Each end of the rail should attach to a corner of the cargo carrier.



3. Bolt each end of the rail to the corner of the cargo carrier with the nut secured from the inside.

# For Your Safety:



## CAUTION

- Distribute load evenly
- Do not exceed the lesser of (1) hitch manufacturer's tongue weight rating; (2) vehicle manufacturer's rear load limit; (3) 500 pounds total cargo.
- Do not transport people or animals on the carrier
- Do not allow cargo to block taillights/vehicle safety equipment
- Securely strap all cargo to the carrier and check frequently during travel
- Do not carry loads that are wider than the carrier platform
- Carrier hitch pins and cotter pins must be secured before each use
- Be certain to secure all items to the carrier
- Do not transport flammable/combustible items on the carrier
- Trailer Hitch Pin sold separately. (12)
- Be sure to attach reflective stickers

