

Ride Cover

Thank you for purchasing the best non-contact motorcycle cover. We take great pride in you choosing Ride Cover to protect your motorcycle. The Ride Cover will protect your motorcycle from rain, snow, hail, sun, scratches, and animals. We designed and continue to modify Ride Cover with the customer in mind. We would also like to inform you that Ride Cover donates 10% of annual profits to the Disable Veterans of America, we support those who support us and with your purchase you do as well. Once you have tried your Ride Cover we encourage you to send us feed back as well as photos of your motorcycle and your cover. Thank you again for your purchase.

Step 1: Parts Check

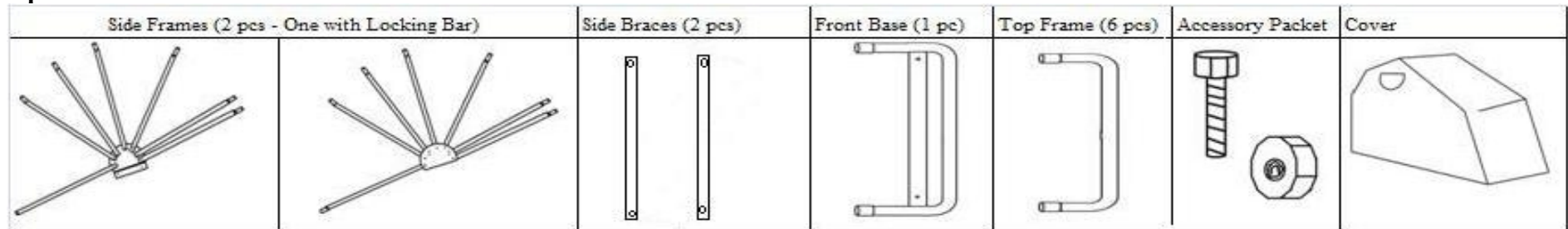

Step 2: Assembly

Note: Tools need will be a 5/16 wrench and a Philips head screw driver.

- A. Join both side frames by inserting 5 of the top frames and the Foot Base to the tubes attached to each corresponding side frame as shown below. DO NOT attach the base frame at this time (refer to illustration on page 2). Ensure that the detent button on each tube snaps into place into the side frame.
- B. Connect the side braces to the holes in the front of the cover at the base frame and the first side frame as shown in the illustration below using the 4 bolts and 4 locking nuts provided in the accessory packet. Ensure that the rounded end of the side brace is down and the angled edge of the side brace matches the angle of the side tube as pictured below.
- C. Insert the remaining top frame in the back of the cover. The back of the cover has been sewn; the front and sides of the cover has Velcro. Looking almost directly below the edge of the window, you will see a large gap in the seam. This is the area in which you will insert the tubes. With the frame standing up, slide one side of the frame in to the seams. Lock the top tube on to the frame. You will have to pull the cover back up the tube to allow slack to insert the remaining tube into the cover to attach the other side.
NOTE: The next 3 steps are done from inside the Ride Cover.
- D. 1 at a time, attach the Velcro straps located on the inside of the ride cover to the corners of each top tube. Ensure that the first free tube is attached to the first free set of Velcro straps, the 2nd to the 2nd, etc., until all tubes are attached. NOTE: You may want to place a weighted object on the front base or have someone hold it down.
- E. Attach the front of the cover to the front base used the Velcro sewn into the base of the cover then the remaining Velcro on the sides. This completes the assembly of the Ride Cover. Ensure that the ride cover is positioned where you want it. Anchoring the Ride Cover to a solid surface is highly encouraged. There are 6 anchors provided with this product (2 for each side frame and 2 for the front base).

Frame View

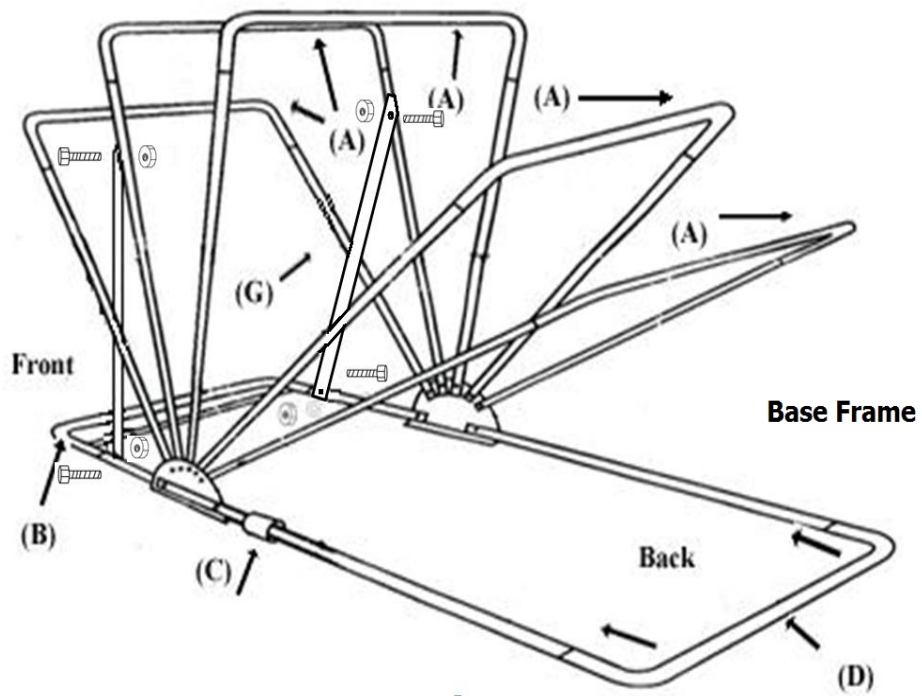

Seam Position Diagram

